

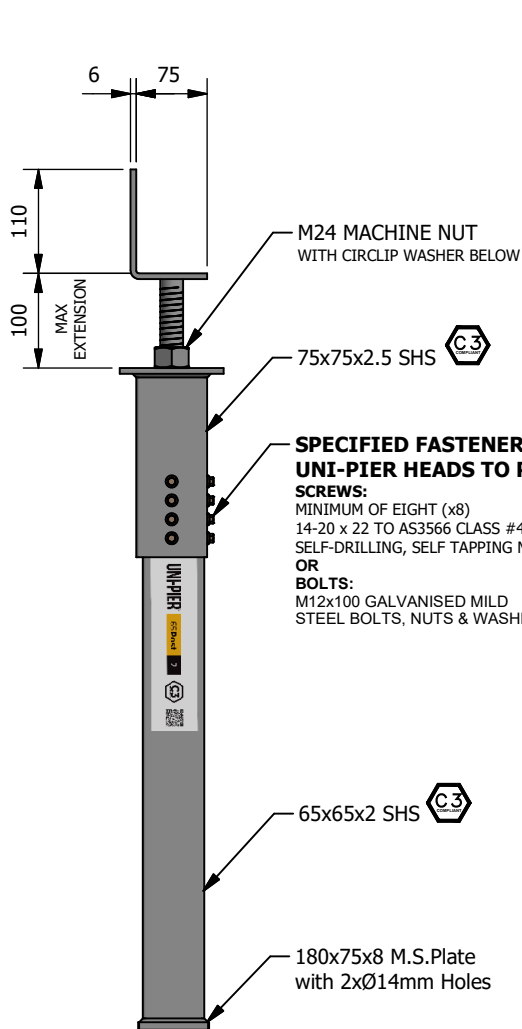

SCREW TOP HEAD (STH) ASSEMBLY

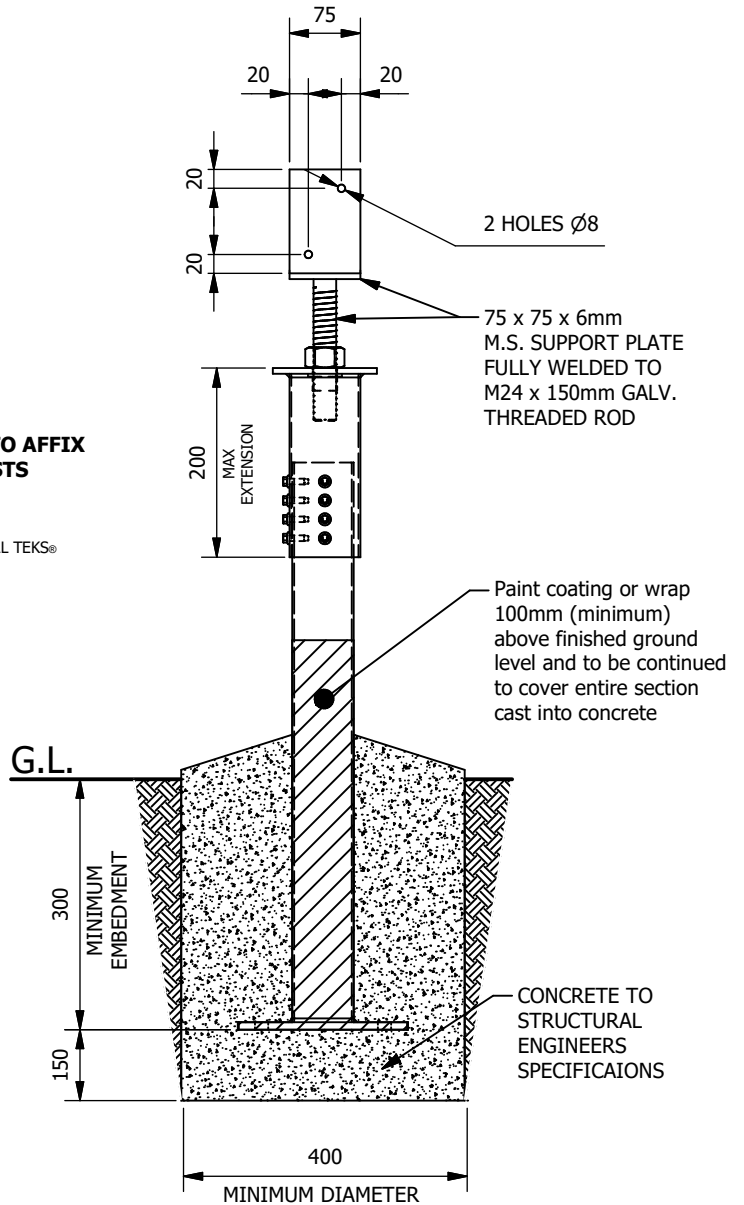

ELEVATION 2



ELEVATION 1

Note: Final approval of specifications by Structural Engineer

FOR ALL UNI-PIER SPECIFICATIONS <https://www.unipier.com.au>
Information on surface treatment between steel post and concrete interface shown in warranty document - Advisory Note #49.1

Drawing No.

Uni Pier 2023-004.6.7

Finish:
BATCH HOT DIPPED GALVANISED

SHEET SIZE
A4

UNI Pier Australia Pty Ltd
ACN 131 900 546
PO BOX 6484 Silverwater NSW 1811
Phone: 1300 366 362
www.unipier.com.au

This drawing is the property of Uni Pier Australia Pty Limited and is protected by Copyright and not transferable. It is illegal to copy, communicate and/or disseminate this drawing to a third party without written permission from Uni Pier Australia Pty Limited and any infringement will be prosecuted under Australian & International Law.

UNI-PIER®



SCREW TOP HEAD (STH) ASSEMBLY

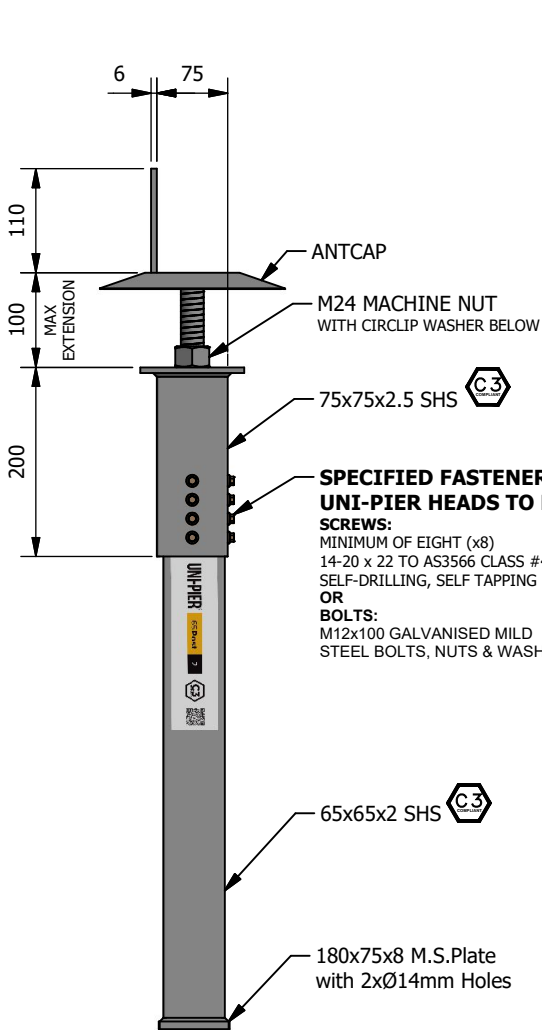

ELEVATION 2

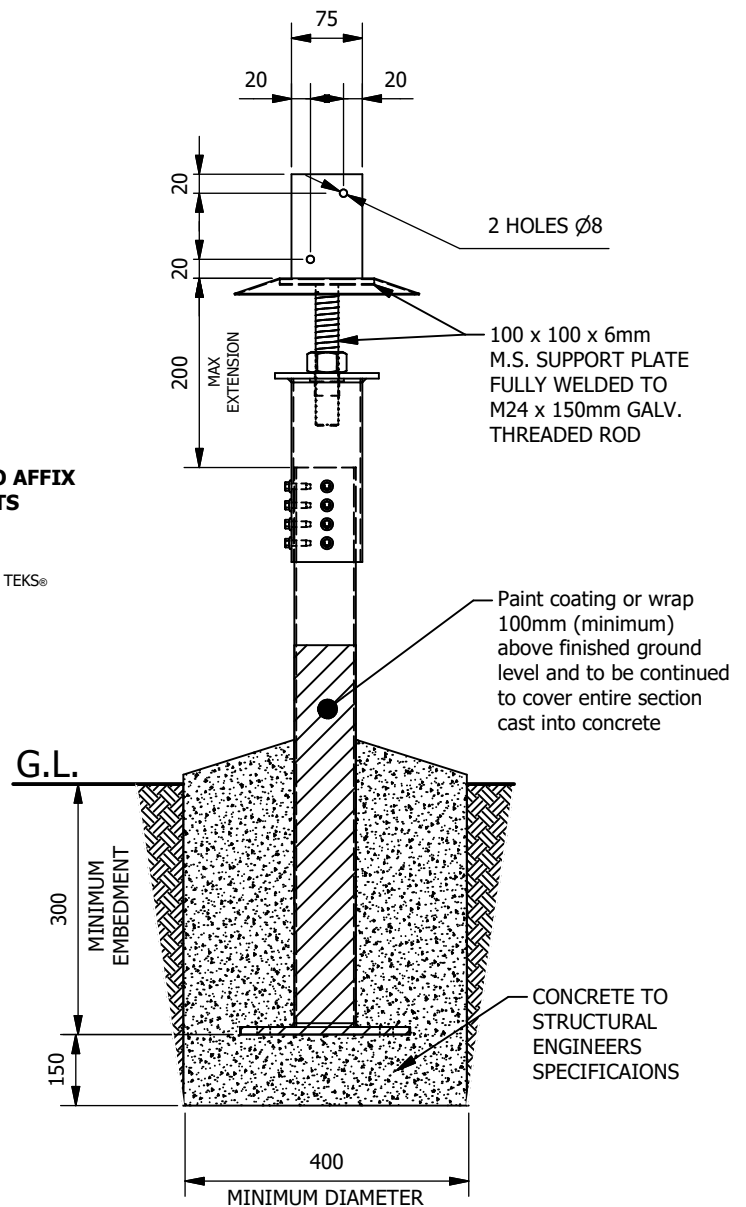

ELEVATION 1

Note: Final approval of specifications by Structural Engineer

FOR ALL UNI-PIER SPECIFICATIONS <https://www.unipier.com.au>

Information on surface treatment between steel post and concrete interface shown in warranty document - Advisory Note #49.1

Drawing No.

Uni Pier 2023-004.8.7

Finish:
BATCH HOT DIPPED GALVANISED

SHEET SIZE
A4

UNI Pier Australia Pty Ltd
ACN 131 900 546
PO BOX 6484 Silverwater NSW 1811
Phone: 1300 366 362
www.unipier.com.au

This drawing is the property of Uni Pier Australia Pty Limited and is protected by Copyright and not transferable. It is illegal to copy, communicate and/or disseminate this drawing to a third party without written permission from Uni Pier Australia Pty Limited and any infringement will be prosecuted under Australian & International Law.

UNI-PIER®